

AVCOM System
Installation Instructions

Index

1) AVCOM EN-1 System Drawings

- AVCOM EN1 System	Page 1
-AVCOM EN1 Evacuation System.....	Page 2
2) RJ45 Plug & RJ45 to Terminal Arrangement.....	Page 3
3) Bus Terminator.....	Page 4
4) AVCOM EN1 Functions.....	Page 5
5) AVCOM Fire Recall Wiring and Functions.....	Page 6
6) AVCOM Evacuation System Functions.....	Page 7
7) Lift Controller Contacts for Evacuation	Page 8
8) AVCOM System Troubleshooting.....	Page 9
9) AVCOM Programming.....	Page 10
10) AVCOM Remote Programming.....	Page 12
11) AVCOM Programming by Handset.....	Page 13
12) Dip Switch arrangements.....	Page 14

Cable description



Multi core wire



CAT5

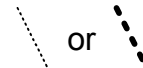

or

Cable used in special cases only

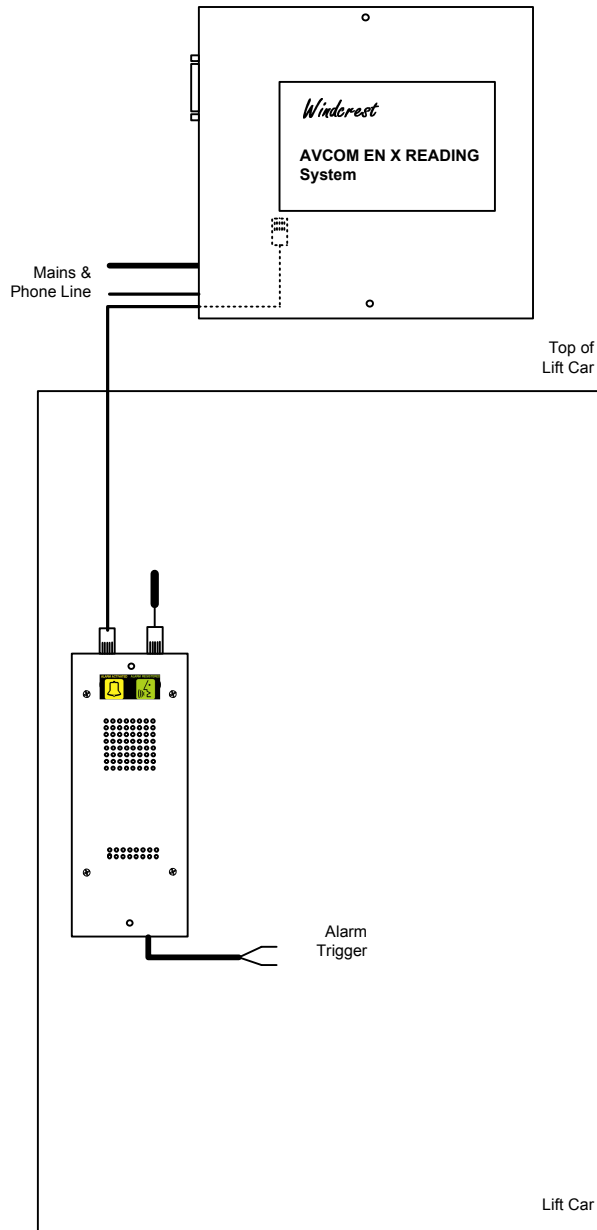

NOTE:

1) All cables used for the system must be Min CAT5

Cable description



Multi core wire



CAT5

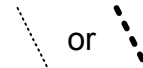

or

Cable used in special cases only

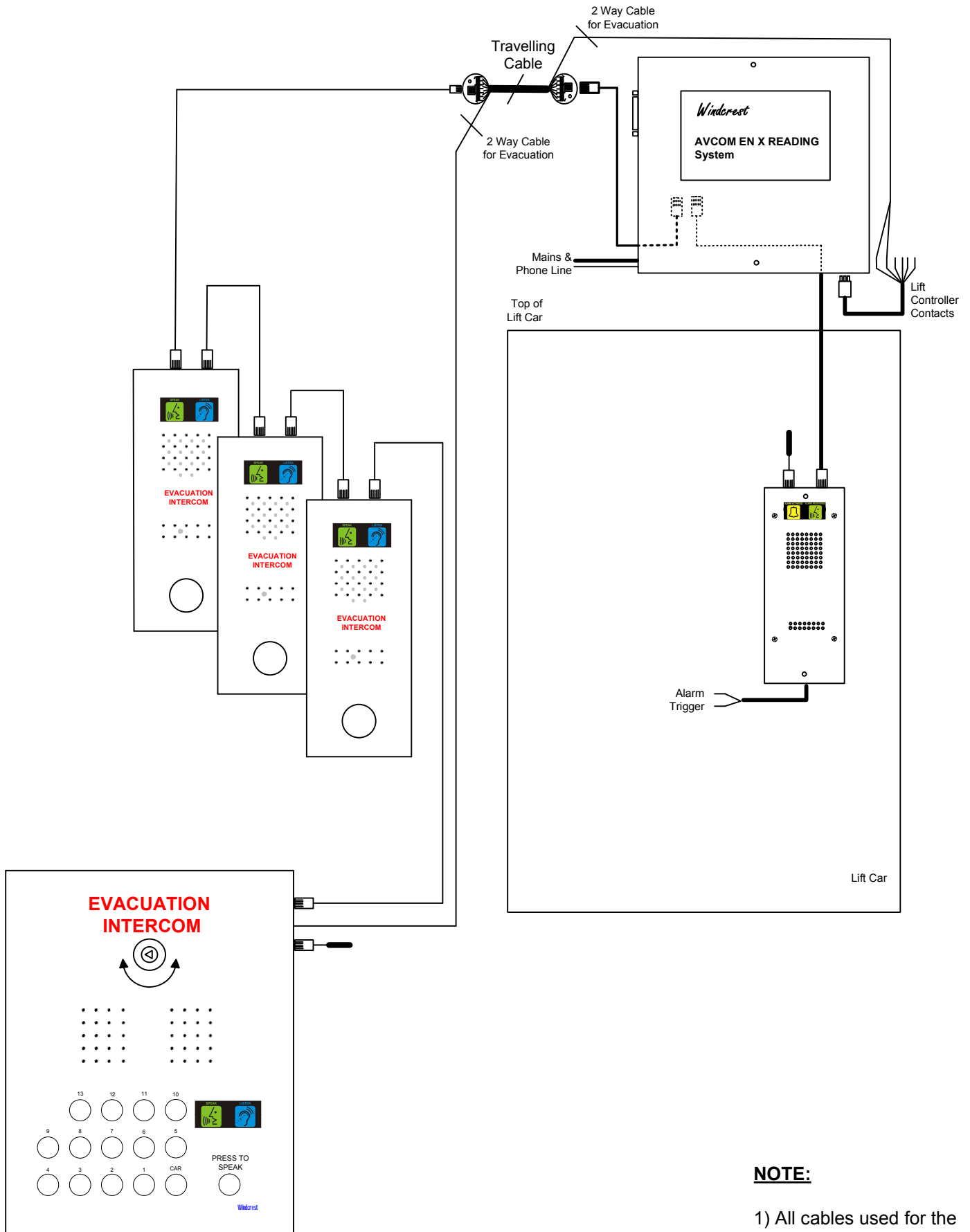

NOTE:

1) All cables used for the system must be Min CAT5

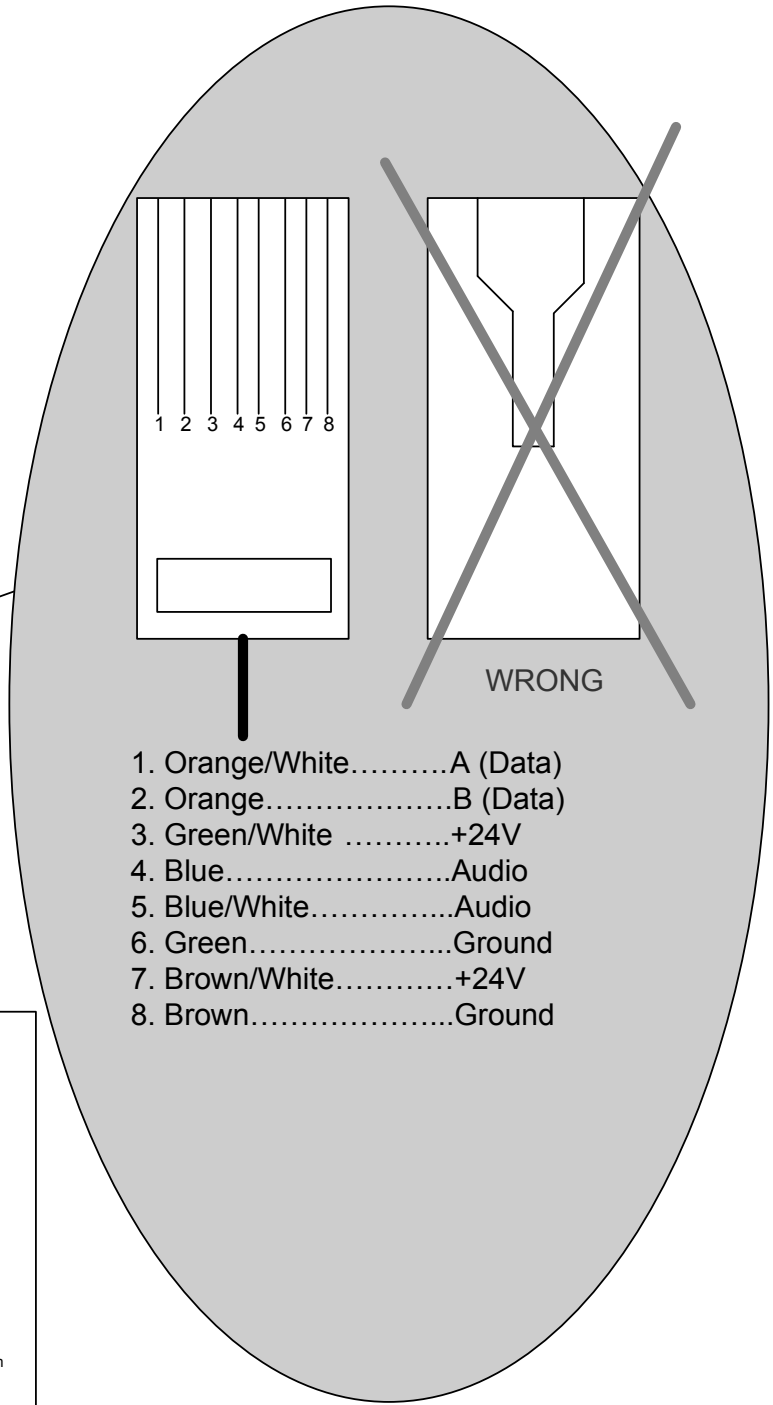
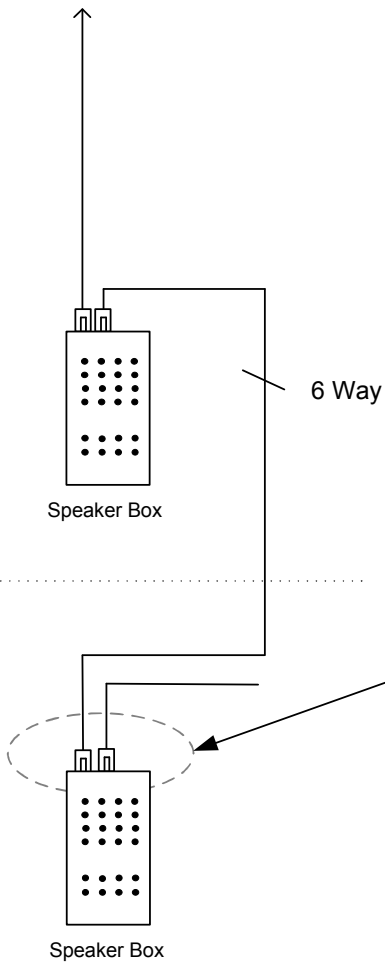

1. Orange/White.....A (Data)
2. Orange.....B (Data)
3. Green/White+24V
4. Blue.....Audio
5. Blue/White.....Audio
6. Green.....Ground
7. Brown/White.....+24V
8. Brown.....Ground

RJ45 to Terminal

A = White
 B = Green
 + = Pink
 GND = Gray
 BT (Audio)= Blue
 BT (Audio) = Yellow

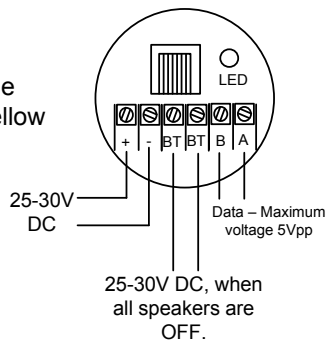

For Troubleshooting, connect the RJ45 to Terminal to the Cable and check the above readings. If the readings are different than above, please contact Windcrest.

LIFT INTERCOM

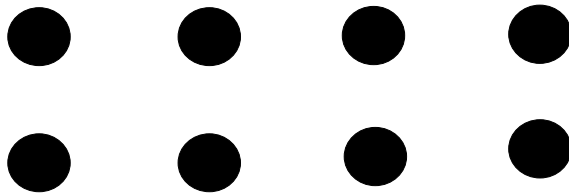
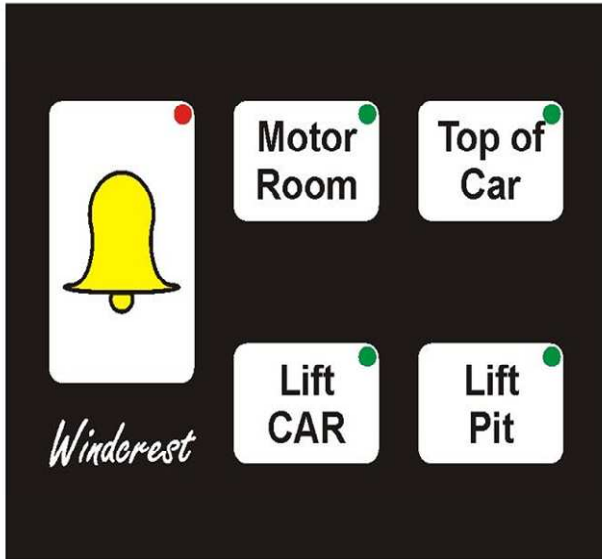
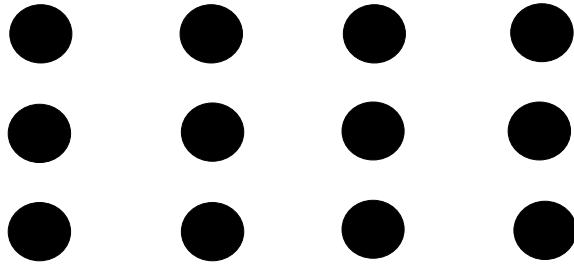

Windercrest

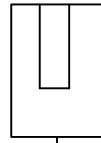

Connect bus terminator to the last outstation on each bus.

RJ 45 Bus Terminator & Speaker Box

Drawing: Terminator

Page: 4

Windercrest LiftBits Ltd

Tel: 0208 795 0333

Fax: 0208 795 0444

AVCOM Functions

Configuration

The AVCOM system can be configured to be EN1 System. Refer to the page no 30. for Programming of the Unit.

Interconnection

All the speaker box assemblies will be connected directly or indirectly via a 6 wire bus (however a CAT5 cable with RJ45 Connectors will be used of installation) to the Control/Power supply unit. This interconnecting wire bus will have a 2 pairs of wires for the Power supply, a pair for the Audio and a pair for the Data.

Operation

Autodialler

The Autodialler will function at all times when the Evacuation Switch has not been operated. If the Car push button is operated, for 3 seconds and the alarm filter allows the signal to trigger the Windcrest autodialler, the Yellow Pictogram will operate and a Speech Synthesis message will be announced in the lift car. This message will instruct and reassure the passenger that a call for assistance is being made.

The autodialler will attempt calling the 1st pre-programmed number. If the person who answers the call, presses * button on the telephone handset, Green Pictogram will operate in the Lift Car. During the conversation a speech synthesis reminder will occur to inform the need to press the Alarm Button in the Lift Car to continue the call. If he fails to do so, the call will terminate. If however the call is to be terminated prior to the automated termination, a "0" on the called persons telephone will terminate the call.

AVCOM Fire Recall Signal

Reading Fire Recall Interface

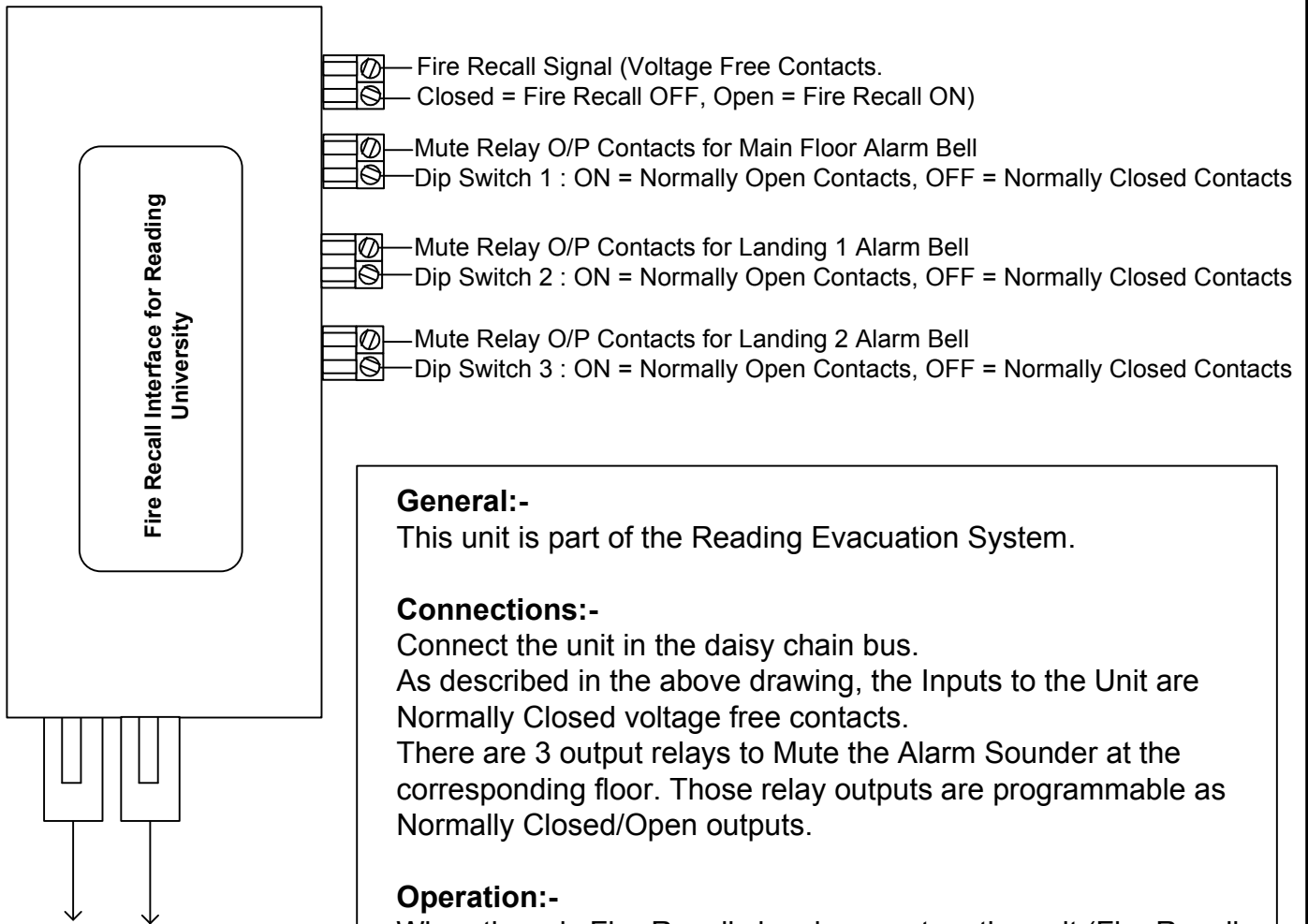

General:-

This unit is part of the Reading Evacuation System.

Connections:-

Connect the unit in the daisy chain bus.

As described in the above drawing, the Inputs to the Unit are Normally Closed voltage free contacts.

There are 3 output relays to Mute the Alarm Sounder at the corresponding floor. Those relay outputs are programmable as Normally Closed/Open outputs.

Operation:-

When there is Fire-Recall signal present on the unit (Fire Recall Inputs - Opened), the landing speaker Push Buttons will be enabled and the buttons will start flashing slowly.

Pressing of the push button on the Landing Speaker, will activate the AVCOM autodialler unit and will dial to the programmed telephone numbers. During the alarm call, both Speak and Listen Pictograms will be ON. The button will illuminate Solid. The relays for the Main Floor and the relevant Landing Speaker will operate to Mute the Alarm Sounder.

At the end of the call, the button will start flashing slowly.

Once the Fire-Recall Signal goes OFF, the Landing Speakers buttons will go OFF.

If anytime, the Evacuation Switch is Turned ON from the Main Panel, pressing of the call button from the Landing Speaker will be registered on the Main Panel. The relay outputs, from the Fire-Recall Interface board, will operate until the Fire Recall Signal is Present.

AVCOM Evacuation Functions

Interconnection

Connect the main Evacuation Panel to the Bus. Connect all the Landing Speakers to the bus. This interconnecting wire bus will have a 2 pairs of wires for the Power supply, a pair for the Audio and a pair for the Data. Refer to Page 28 for the Lift Controller Contacts and the Evacuation Switch Contacts (Yellow & Blue) from the Main Panel.

Operation

To activate the evacuation system, place the EURO switch in the ON position. All the LEDs for the Landing Speakers and the Lift Car will flash for 5 seconds when the system is analysing the Outstations. After 5 seconds, the LEDs on the main Panel will be ON for the outstations which are present working (i.e. Data Link is Working) for 3 seconds. All LEDs will be switched OFF on the Pit, Top Of Car, MRL Speaker Keypads. The "Listen" Pictogram will be ON to indicate that the system is ready.

At the all Landing Speakers Call Button will Flash slowly to Indicate System is ON. On pressing the CALL button on any outstation, the LED will start flashing faster to indicate placement of a call. At the same time the corresponding LED for that outstation and a buzzer will operate. The flashing and buzzing will continue till the person on the Main Control Panel answers the call by pressing the corresponding button. At the point the voice link is opened, the LED on the calling outstation and main panel will remain ON till the voice link is terminated.

When Voice Link is active, press to speak button will control the speech from the master station. When press to speak button is released, Main Control Panel's microphone will be muted and outstation microphone will be ON, and Main Control Panel's microphone is muted. When press to speak button is pressed and Hold, Outstation microphone will be muted and Master Panel microphone will be ON. Pictograms at the Main Control Panel and the Landing Speaker will show the status of speak/listen. i.e. when the speaker box's Mic will be ON, "Speak" Pictogram will illuminate and when the Speaker Box's Mic will be OFF, "Listen" Pictogram will illuminate.

A call can be made to any of the Outstation by simply pressing the button for that outstation on the Main Control Panel. As soon as the button is pressed the LED on both the outstation and the Master Panel will be steady ON and a two way communication is possible via press to speak button on the Main Control Panel.

The call can be terminated by the pressing the same button again at which point LEDs on the outstation and Main Control Panel will go off and the Pictograms at the Landing Speakers will be switched off and at the Main Panel "Listen" Pictogram will illuminate to indicate the system status.

When Evacuation Switch is turned OFF, Both the Pictograms at the Main Control Panel will be switched off and Push Button LED at all the Landing Speakers will be turned OFF. Top of Car, Pit, MRL speaker units' keypad will be live again.

Note :- When Evacuation system is ON, System will not allow any other operations. When Evacuation System is turned ON, it will abandon any ongoing operation. i.e. Intercom, Autodialler.

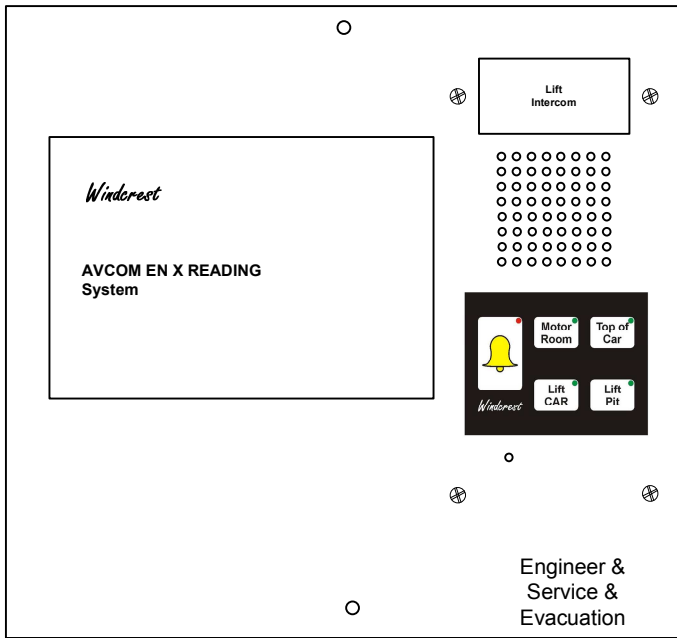

Yellow & Blue (For Evacuation)- Orange & White from Evacuation Panel if present.

Pink & Gray
 Engineer ON/OFF Contacts.
 Closed – Engineer ON Site
 Open – Engineer Off Site

White & Green
 Service Period ON/OFF Contacts.
 Closed – Service Period

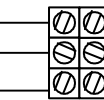
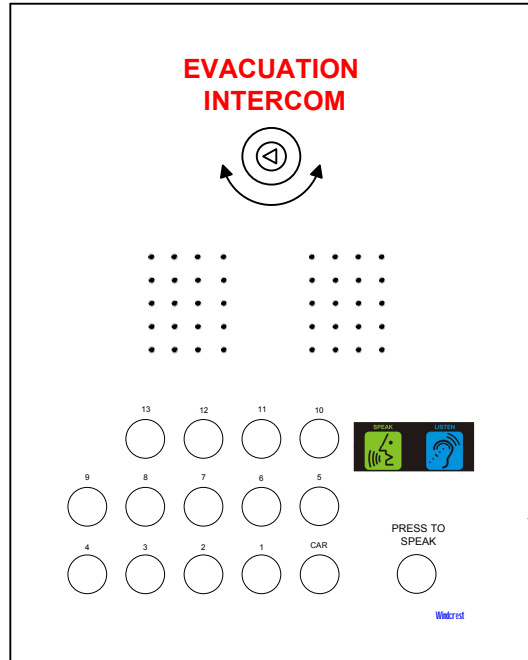

Blue or Orange - Common
 Green or White- Normally Open
 Yellow- Normally Closed

Orange ————
 White ————
 To Main AVCOM Unit (Yellow & Blue)

Evacuation Lift Controller Spare Contacts

Background Operation

The system will make the automated 3 day test calls to a Central Station in accordance to EN81-28.

Troubleshooting

If LEDs on the Keypad of the outstation speakers, both pictograms in the Lift Car starts flashing continuously, it indicates data failure to that point. i.e. If Lift car speaker's both pictogram flash continuously, it indicates data link failure to Lift car speaker. This can occur due to data cable failure or incorrect programming. i.e. If system is programmed for EN1, Top of Car, Pit and MRL/Motor Room speaker will not receive the Data.

If Pictograms at the Main Fire Fighting Landing and the MRL-FF Landing/Top Landing Speaker for Fire Fighting start flashing continuously, it indicates data link is failed at those outstations. This can occur due to data cable failure or incorrect programming. i.e. if system is NOT programmed for Fire Fighting, FF Main Landing and Top Landing Speaker will not receive the Data.

On the Top of Car, MRL/Motor Room, Pit Speaker, there is a keypad representing all the buttons for Top of Car, Car, Pit and MRL/Motor Room. In the idle mode, those all LEDs will be lighting up in the loop to indicate system is live and Data Link is available to the speaker. If any of the button's LED does not light up in the sequence, it indicates that Outstation Speaker is not programmed in the system or that Outstation Speaker is not present in the system, which may be due to data failure to the outstation, Outstation Speaker not connected to the system or Outstation Speaker itself may have gone faulty.

For Example, if the Main Unit is programmed as EN3 system which is Lift Car, Top of Car and Lift Pit. On the Top of Car and Pit KeyPad Motor Room button's LED will not light up any time.

Note: During the programming of the unit via Windcrest Handheld Programmer, Unit will not scan any outstations. i.e. no data link, which will result in the flashing of the all the LEDs at all outstation speakers.

Programming of the AVCOM System

All input data must be entered by the pressing of the “Enter” button and go back a step by pressing “Cancel” button.

Pressing “Enter ” button on the programmer would show 2 options. “1” to choose programming and “5” to check Programming content.

Press 1 to choose programming.

1. “Unit Type EN?” Press 1 for EN1.
2. “2 LIFT CAR SPKs?”. Press 1 for 2COP arrangement. Press 0 for 1 COP.
3. “Evacuation System?” and Press 1 if Evacuation system is connected and 0 if Evacuation system is not connected . If the Evacuation System is NOT programmed, the Evacuation Reading Interface Unit will not work.
If Unit is programmed for Autodialler functions, i.e.EN1/EN3/EN4 then only following options will be shown.
- 3A. “Landing Spks?” This option will be available if the Evacuation System is programmed. Key in the No. of Landing Speakers. (Do not include the landing where the Main Switching Panel is Installed.)
4. CB Hot Line? Press 1 for CB Hot Line and 0 for non CB hot Line.
If CB Hot Line option is selected, telephone number options will not be available.
5. Enter 1st number
6. Enter 2nd number
7. Enter 3rd number
8. Enter 4th number
9. “Auto Test Call?” Press 1 to Enable Auto-Test Call. Press 0 to Disable.
10. “Test Call Hours?” This option will be available if the Auto-Test Call is Enabled.
Program the test call frequency between 01 to 99 Hours. Default Test Call frequency is 70 hours.

If Auto Test Call is Disabled the Windcrest Programmer display will show “Windcrest” and “System Ready” on the idle screen. i.e. when unit is not in the programming or not in any mode of operation.
if Auto Test Call is Enabled, the Windcrest Programmer Display will show “Windcrest” and “HH:MM:SS” (Remaining Time before the Next Test Call).
11. If Auto Test Call is enabled, Enter C/S number? (central station number – For Automated Test Calls) else Enter 5th Number (Helper).
12. Auto Pictogram? Press 1 to change pictogram automatically and 0 to disable automatic switching of the pictogram. Default 0.
13. Ignore DTMF? Press 1 to disable DTMF detection and 0 to Enable DTMF detection. Default 0.
14. RPA number? Remote Programming Access number. Default 1234. This is the Pass Code to program the unit from the remote. i.e. by Incoming Call.
15. Call duration? Enter 1 to 9 minutes call duration.

Programming of the AVCOM System

16. Instant Trigger? Press 1 for Instant Trigger. Press 0 for 3 second trigger delay.
17. AlarmPush N/C? Press 1 for Normally Closed Alarm Push, Press 0 for Normally Open Alarm Push.
18. Autojump next? Press 1 to Enable autojump and 0 to disable autojump.
When AutoJump is Enabled, by triggering the Unit, unit will dial the 1st Telephone number and will wait for the acknowledgement * from the recipient of the call. If * is not received within 30 seconds of the Dialling, unit will jump to the 2nd Telephone Number. The unit will continue Jumping to the Next number unless * is received from the call recipient (The unit will jump till the 5th telephone number and then will stop jumping).
19. Lift No? Use 2 & 8 Key to scroll. Lift Number Can be programmed as single 0-9 or A-Z. Press Enter after correct Lift Number is selected.
20. ID Message Type? Press 1 for Recorded Message as Identification Message. Press 0 for Contract Number as Identification Message.
- 20A. If 1 (Recorded Message Type) is selected, Connect the normal telephone handset to the unit and Press "1" on the programmer to start Recording Via Telephone Handset. After completing the recording. Press 2 to Play the recorded Message in the Lift Car. If the message is not acceptable, Press 1 to re-record or Press Enter to Go to the Next Menu.
- 20B. If 0 (Contract Number as Message Type) is selected Key in the Contract Number and Press Enter.
21. Voice Identify? Press 1 to enable Voice Identify and 0 to disable voice identify.
When voice identify is Enabled, the unit will announce the Recorded Message Automatically after dialling the number. After the message the call recipient is required press * to acknowledge. The message will be replayed if the * is not received.
22. Have you finished? Press 1 to finish programming, Press 0 to restart programming and Press 5 to check programming content..

Remote Programming of the AVCOM System

To remotely program the Unit,

1. Call the Main Unit from the Normal Telephone Handset or Mobile.
2. The unit will answer the incoming call with the message "Answering Incoming Call".
3. Wait for 2 seconds after the Message and Press *RPA CODE# on the telephone handset.
i.e. Default RPA Code will be 1234 so *1234# is required to be pressed. When the unit will accept the RPA Code, the unit will beep once. If the RPA code is not entered Correctly then unit will beep three times.
4. Once the RPA Code is accepted then use the following codes to Program :
Please Note if the unit accepts the string, unit will beep once at the end of the string. If anytime wrong parameter is being detected, unit will beep three times. Retry after 2 seconds.
It is not necessary to program all the parameters. Programming can be terminated anytime once the desired parameters are set.

1st Telephone Number	*11#Telephone Number#
2nd Telephone Number	*12#Telephone Number#
3rd Telephone Number	*13#Telephone Number#
4th Telephone Number	*14#Telephone Number#
5th Telephone Number	*15#Telephone Number#
Contract Number	*16#Contract Number#
Auto-Test	*20#N# N = 1 to Enable, N = 0 to Disable.
Auto-Jump	*21#N# N = 1 to Enable, N = 0 to Disable.
Auto-Pictogram	*22#N# N = 1 to Enable, N = 0 to Disable.
CB Hot Line	*23#N# N = 1 to Enable, N = 0 to Disable.
Voice ID	*24#N# N = 1 to Enable, N = 0 to Disable.
Instant Trigger	*25#N# N = 1 to Enable, N = 0 to Disable.
Identification Message Type	*27#N# N = 1 for Recorded Message, N = 0 for Contract Number.
Alarm-Filter	*28#N# N = 1 to Enable, N = 0 to Disable

Alarm-Filter Relay outputs are on the AVCOM boards. C & NO – Normally Open Contacts, C & NC – Normally Closed Contacts.

DTMF Detection OFF	*29#N# N = 1 to Disable Detection, N = 0 to Enable Detection
Call Duration	*30#N# N = 1 to 9 Minutes.
Evacuation System	*31#N# N = 1 for Evacuation System, N = 0 for Non Evacuation System.
Auto-Test Call Hours	*40#NN# NN = 01-99 Hours
Lift Number	*41#NN#

NN = 00 – LIFT NUMBER 0	NN = 10 – LIFT NUMBER A	NN = 20 –LIFT NUMBER K	NN = 30 – LIFT NUMBER U
NN = 01 – LIFT NUMBER 1	NN = 11 – LIFT NUMBER B	NN = 21 –LIFT NUMBER L	NN = 31 – LIFT NUMBER V
NN = 02 – LIFT NUMBER 2	NN = 12 – LIFT NUMBER C	NN = 22 –LIFT NUMBER M	NN = 32 – LIFT NUMBER W
NN = 03 – LIFT NUMBER 3	NN = 13 – LIFT NUMBER D	NN = 23 –LIFT NUMBER N	NN = 33 – LIFT NUMBER X
NN = 04 – LIFT NUMBER 4	NN = 14 – LIFT NUMBER E	NN = 24 –LIFT NUMBER O	NN = 34 – LIFT NUMBER Y
NN = 05 – LIFT NUMBER 5	NN = 15 – LIFT NUMBER F	NN = 25 –LIFT NUMBER P	NN = 35 – LIFT NUMBER Z
NN = 06 – LIFT NUMBER 6	NN = 16 – LIFT NUMBER G	NN = 26 –LIFT NUMBER Q	
NN = 07 – LIFT NUMBER 7	NN = 17 – LIFT NUMBER H	NN = 27 –LIFT NUMBER R	
NN = 08 – LIFT NUMBER 8	NN = 18 – LIFT NUMBER I	NN = 28 – LIFT NUMBER S	
NN = 09 – LIFT NUMBER 9	NN = 19 – LIFT NUMBER J	NN = 29 – LIFT NUMBER T	

Number of Landing Speakers	*42#NN# NN = 01-24
Full EN 81-28	*45#N# N = 1 to Enable, N = 0 to Disable (Default).

The flashing of the Yellow Pictogram will indicate the Alarm state. {Alarm state/flashing of Yellow Pictogram can be cleared by making an Alarm Call and transmitting/pressing DTMF tone "7" by the call recipient or calling the unit and transmitting/pressing DTMF tone "7"}.

5. To terminate the Remote Programming Press *00#. The unit will announce thank you and end the call.

Local Programming Vial Telephone Handset :

1. Connect the Telephone Handset to the Unit.
2. Key In *1234# is required to be pressed. Unit will beep once to acknowledge the code.
3. Use the following codes to Program :

Please Note if the unit accepts the string, unit will beep once at the end of the string.
If anytime wrong parameter is being detected, unit will beep three times. Retry after 2 seconds.

It is not necessary to program all the parameters. Programming can be terminated anytime once the desired parameters are set.

1st Telephone Number	*11#Telephone Number#
2nd Telephone Number	*12#Telephone Number#
3rd Telephone Number	*13#Telephone Number#
4th Telephone Number	*14#Telephone Number#
5th Telephone Number	*15#Telephone Number#
Contract Number	*16#Contract Number#
Auto-Test	*20#N# N = 1 to Enable, N = 0 to Disable.
Auto-Jump	*21#N# N = 1 to Enable, N = 0 to Disable.
Auto-Pictogram	*22#N# N = 1 to Enable, N = 0 to Disable.
CB Hot Line	*23#N# N = 1 to Enable, N = 0 to Disable.
Voice ID	*24#N# N = 1 to Enable, N = 0 to Disable.
Instant Trigger	*25#N# N = 1 to Enable, N = 0 to Disable.
Identification Message Type	*27#N# N = 1 for Recorded Message, N = 0 for Contract Number.

Alarm-Filter *28#N# N = 1 to Enable, N = 0 to Disable

Alarm-Filter Relay outputs are on the AVCOM boards. C & NO – Normally Open Contacts, C & NC – Normally Closed Contacts.

DTMF Detection OFF *29#N# N = 1 to Disable Detection, N = 0 to Enable Detection

Call Duration *30#N# N = 1 to 9 Minutes.

Evacuation System *31#N# N = 1 for Evacuation System, N = 0 for Non Evacuation System.

Auto-Test Call Hours *40#NN# NN = 01-99 Hours

Lift Number *41#NN#

NN = 00 – LIFT NUMBER 0	NN = 10 – LIFT NUMBER A	NN = 20 –LIFT NUMBER K	NN = 30 – LIFT NUMBER U
NN = 01 – LIFT NUMBER 1	NN = 11 – LIFT NUMBER B	NN = 21 –LIFT NUMBER L	NN = 31 – LIFT NUMBER V
NN = 02 – LIFT NUMBER 2	NN = 12 – LIFT NUMBER C	NN = 22 –LIFT NUMBER M	NN = 32 – LIFT NUMBER W
NN = 03 – LIFT NUMBER 3	NN = 13 – LIFT NUMBER D	NN = 23 –LIFT NUMBER N	NN = 33 – LIFT NUMBER X
NN = 04 – LIFT NUMBER 4	NN = 14 – LIFT NUMBER E	NN = 24 –LIFT NUMBER O	NN = 34 – LIFT NUMBER Y
NN = 05 – LIFT NUMBER 5	NN = 15 – LIFT NUMBER F	NN = 25 –LIFT NUMBER P	NN = 35 – LIFT NUMBER Z
NN = 06 – LIFT NUMBER 6	NN = 16 – LIFT NUMBER G	NN = 26 –LIFT NUMBER Q	
NN = 07 – LIFT NUMBER 7	NN = 17 – LIFT NUMBER H	NN = 27 –LIFT NUMBER R	
NN = 08 – LIFT NUMBER 8	NN = 18 – LIFT NUMBER I	NN = 28 – LIFT NUMBER S	
NN = 09 – LIFT NUMBER 9	NN = 19 – LIFT NUMBER J	NN = 29 – LIFT NUMBER T	

Number of Landing Speakers *42#NN# NN = 01-24

Full EN 81-28 *45#N# N = 1 to Enable, N = 0 to Disable (Default).

The flashing of the Yellow Pictogram will indicate the Alarm state. {Alarm state/flashing of Yellow Pictogram can be cleared by making an Alarm Call and transmitting/pressing DTMF tone "7" by the call recipient or calling the unit and transmitting/pressing DTMF tone "7"}.

Recording the Message *26#1# . Start Recording after the beep. Another beep will indicate the end of the recording.

Playing the recorded message *26#0#.Message will be heard in the telephone handset.

4. To come out of the programming Press *00#. The unit will announce beep.

All AVCOM Speakers have unique address. This address is set by the Dip Switch on the back of the each speaker box. Following are the arrangements for the Dip Switch for the different speaker box.

Note: X – Do Not Care

	1	2	3	4	5	6
Car Speaker	ON	Off	Off	Off	Off	X
Top Of Car Speaker	Off	ON	Off	Off	Off	X
Pit Speaker	ON	ON	Off	Off	Off	X
MRL Speaker (For EN4 & FF)	Off	Off	ON	Off	Off	X

2COP Speaker This address is special and to be set at factory only.

Evacuation Landing Speaker	1	2	3	4	5	6
Landing 1	ON	Off	Off	Off	Off	X
Landing 2	Off	ON	Off	Off	Off	X
Landing 3	ON	ON	Off	Off	Off	X
Landing 4	Off	Off	ON	Off	Off	X
Landing 5	ON	Off	ON	Off	Off	X
Landing 6	Off	ON	ON	Off	Off	X
Landing 7	ON	ON	ON	Off	Off	X
Landing 8	Off	Off	Off	ON	Off	X
Landing 9	ON	Off	Off	ON	Off	X
Landing 10	Off	ON	Off	ON	Off	X
Landing 11	ON	ON	Off	ON	Off	X
Landing 12	Off	Off	ON	ON	Off	X
Landing 13	ON	Off	ON	ON	Off	X
Landing 14	Off	ON	ON	ON	Off	X
Landing 15	ON	ON	ON	ON	Off	X
Landing 16	Off	Off	Off	Off	ON	X
Landing 17	ON	Off	Off	Off	ON	X
Landing 18	Off	ON	Off	Off	ON	X
Landing 19	ON	ON	Off	Off	ON	X
Landing 20	Off	Off	ON	Off	ON	X
Landing 21	ON	Off	ON	Off	ON	X
Landing 22	Off	ON	ON	Off	ON	X
Landing 23	ON	ON	ON	Off	ON	X
Landing 24	Off	Off	Off	ON	ON	X
Landing 25	ON	Off	Off	ON	ON	X
Landing 26	Off	ON	Off	ON	ON	X
Landing 27	ON	ON	Off	ON	ON	X
Landing 28	Off	Off	ON	ON	ON	X
Landing 29	ON	Off	ON	ON	ON	X
Landing 30	Off	ON	ON	ON	ON	X
Landing 31	ON	ON	ON	ON	ON	X